

Electronic feeder

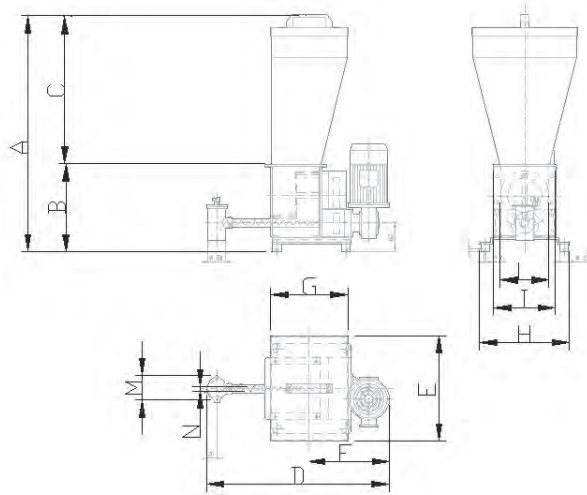

Dimensions in mm

Model	A	B	C	D	E	F	G	H	I	L	M	N
ACD 04	684,5	247	437,5	530,5	305	232	225	260	230	142	75	16
ACD 08	684,5	247	437,5	530,5	305	232	225	260	230	142	75	16
ACD 20	684,5	247	437,5	530,5	305	232	225	260	230	142	75	30
ACD 40	684,5	247	437,5	530,5	305	232	225	260	230	142	75	30

	Minimum Capacity	Maximum Capacity	Installed Power (W)	Hopper volume	Weight (Feeder+Elec. Panel)
ACD 04	0,50 dm ³ /h	8,00 dm ³ /h	90	16 liters	24 + 3 kg.
ACD 08	1,00 dm ³ /h	16,00 dm ³ /h	90	16 liters	24 + 3 kg.
ACD 20	2,40 dm ³ /h	40,00 dm ³ /h	90	16 liters	24 + 3 kg.
ACD 40	5,00 dm ³ /h	80,00 dm ³ /h	90	16 liters	24 + 3 kg.

TECHNICAL FEATURES OF THE EQUIPMENT CAN BE MODIFIED WITHOUT ANY OBLIGATION OF NOTICE. DATA MAY BE NOT FULLY IN ACCORDANCE WITH MARKET VERSIONS.

effegielle s.r.l.
imeco
automazioni



Via Amedeo Tonani, 4/b
26030 Malagnino - Cremona - Italia

Tel. +39.0372.49.68.26
Fax +39.0372.49.68.47

info@imeco.org www.imeco.org

ACD

**YIELD MANAGEMENT
DOSING**



ACD | Electronic Feeder

ACD
effegielle



effegielle s.r.l.
imeco
automazioni



CONCEPTION

The ACD is essentially composed of :

1	Surge hopper
2	product mixer
3	Drive motor
4	Extracting screw
5	Operator panel

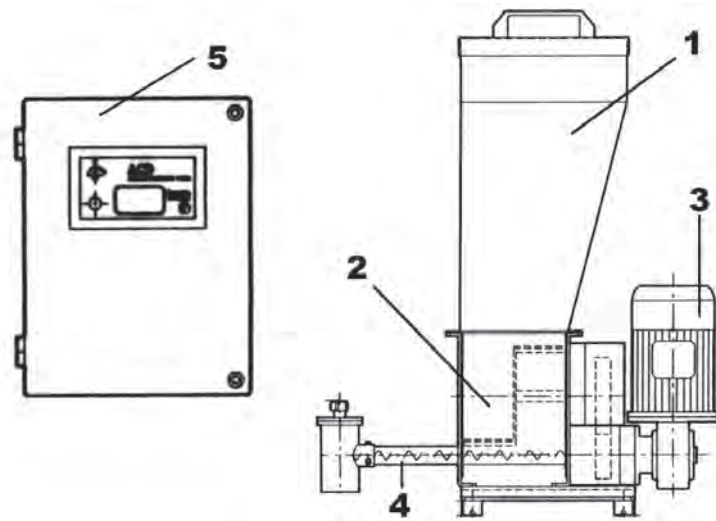

PURPOSE OF THE MACHINE

The ACD has been manufactured for the accurate volumetric continuous dosing of very small quantities of powders like additives, flour improvers etc.



RELIABILITY

The careful design and the easy construction of this machine, assure a high reliability.

The machine is completely made in stainless steel. Are available both versions stainless steel painted and stainless steel polished.



The machine is equipped with a MIXER in order to avoid product bridges and clogging inside the hopper.

In order to reduce the installed power the ACD is equipped with only one motor that drives both, extracting screw and MIXER.

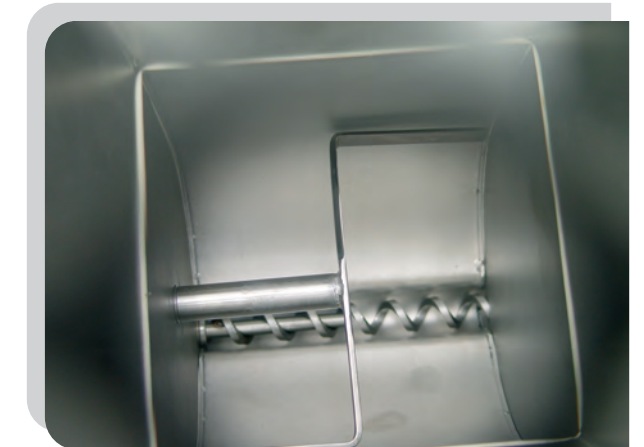

TYPICAL APPLICATION

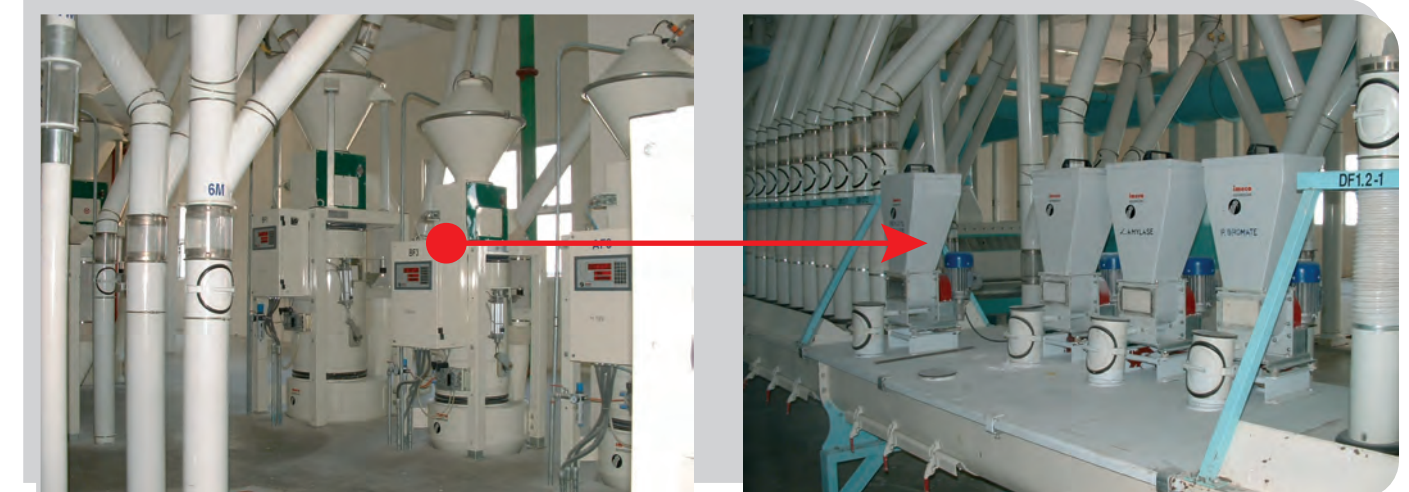

A typical application is the accurate continuous dosing of improvers during flour production before the transfer to storage silos.

Our ACD is prepared to be driven by an electronic scale in order to adjust the dosing capacity according with main flow capacity changing.