

Cereals Automatic Dampening Controller

IDM

PRODUCTION CONTROL
MOISTURE CONTROL

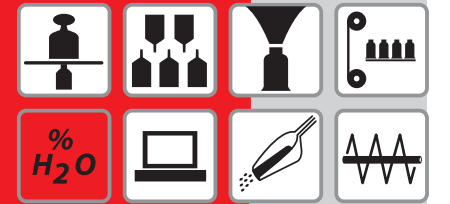

IDM Automatic Dampening Controller

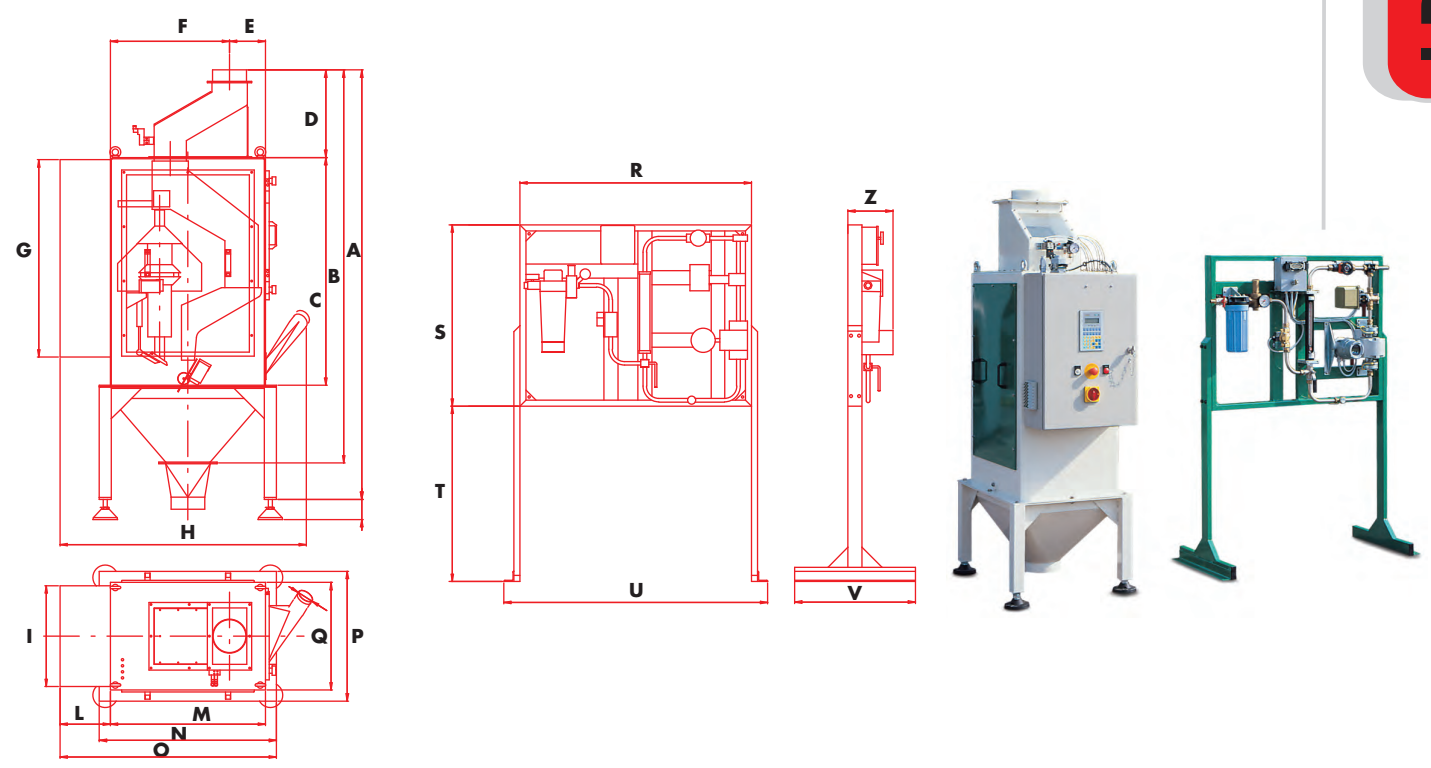

Dimensions in mm															
Model	A	B	C	D	E	F	G	H	I	L	M	N	O	P	Q
IDM 30	2131	1951	1131	435	178	592	980	1224	500	250	770	880	1075	644	534
IDM 45	2131	1954	1131	438	189	581	980	1224	500	250	-	880	1075	744	634
Model	R	S	T	U	V	Z									
IDM 30	1150	900	870	1310	600	230									
IDM 45	1150	900	870	1310	600	230									

	Maximum Wheat Flow rate	Maximum Water delivered	Requested Aspiration	Air Consumption	Installed Power	Main part Weight	Water Panel Weight
	Till to		m3/min	Nl / min (6 bar)	(kW)	(kg)	(kg)
IDM 30	35 t/h	2000 l/h	4	3,9	0,4	340	65
IDM 45	50 t/h	2000 l/h	4	3,9	0,4	400	75

IDM
effegielle



effegielle s.r.l.
imeco automazioni



effegielle s.r.l.
imeco automazioni



Via Amedeo Tonani, 4/b
26030 Malagnino - Cremona - Italia
Tel. + 39.0372.49.68.26
Fax +39.0372.49.68.47
info@imeco.org www.imeco.org

MACHINE PURPOSE

The Automatic Dampening Controller Mod. IDM, has been designed to measure and regulate cereal moisture before milling.

IDM is composed of two separate elements :



1. The measuring device which detect cereal parameters necessary to regulate the water quantity to be added
2. The water panel which regulate the water flow rate added during dampening process

IDM machine does the following operations :

- Inlet dry product moisture measurement
- Inlet product flow rate
- Automatic water calculation and addition
- Total Amount of dry product processed and quantity of added water
- Supervisor control systems interface
- Operator interface



CONCEPTION

The cereal under control is conveyed into the IDM through the surge pipe.

Here the IDM measures the instantaneous cereal flow rate and sampling a small amount of product, measures the temperature, bulk density and moisture (%).

With these information, the machine calculates the exact water flow rate to be added and sends this signal to the water panel that continually controls the dampening process.

The process control is fully automatic and only requires under operative conditions, the desired final moisture (called also moisture set point).

OPERATING

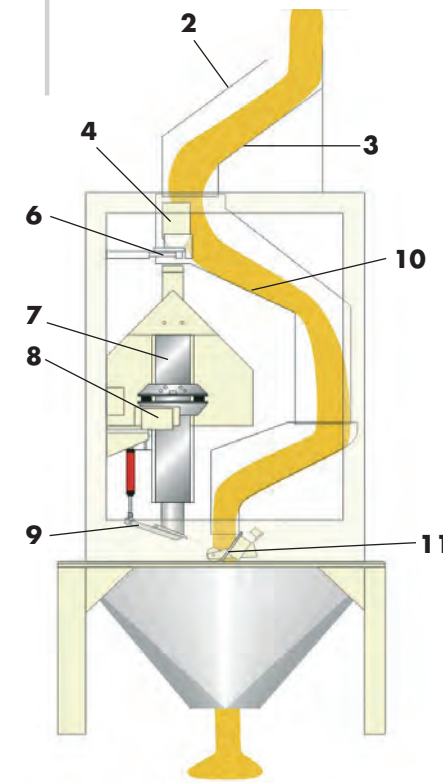

Product inlet (item **2** and **3**) allows to stabilize product speed and conveys it into the fall box (**4**).

When the shutter (**6**) is closed, the product fills the fall box (**4**) and then it flows over, passing through the second chute (**10**).

When the shutter (**6**) is open, the product fills the sampling hopper (**7**). The exceeded fills into the second chute (**10**).

The sampled product in the sampling hopper (**7**) is passed through a microwave beam; the water content of the product sample is determined by the microwave beam attenuation.

The sampling hopper (**7**) is supported by two load cells (**8**) that allow to know the mass of product which is passed through by the microwave beam.

Knowing the water content and the product weight, the IDM calculates the moisture percent.

Once the measurement is done, the sample is discharged into the main chute by means of the flap (**9**).

The product flow rate is measured by slanting plate (**11**). The flow rate measurement is not performed when the sampling hopper (**7**), is charging or discharging product sample (avoiding noised measurements during the sampling operations).

The on board electronic control calculates the amount of water necessary to reach the final moisture set point inserted by the operator.

Variations of the product characteristics or flow rate are automatically acknowledged and compensate by the IDM.

To allow the moisture process, in case the IDM machine doesn't work, the water panel is equipped with manual devices (systems) to regulate and visualize the quantity of added water.

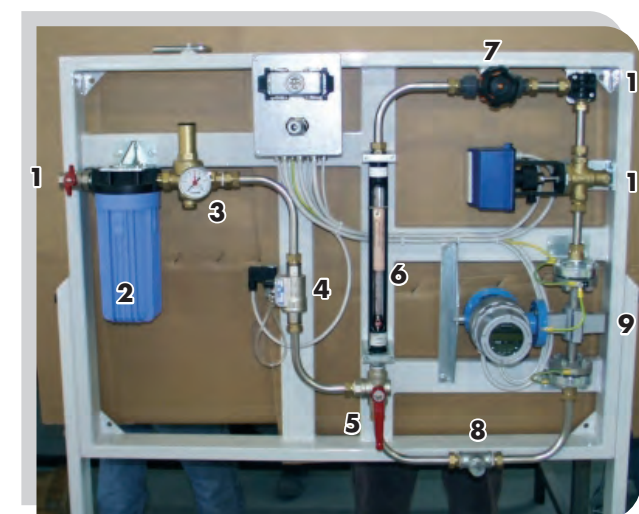

PART LIST

1	ON / OFF Manual valve
2	Polypropylene water filter
3	Water pressure regulator
4	ON / OFF pneumatic valve
5	Manual diverting valve
6	Manual flow meter
7	Manual regulating valve
8	Emptying point
9	Electronic water flow meter
10	Motorized regulating valve
11	Output point